

SafeGuard™ H2O

On-Site Stannous Generation System

As a cost-effective and efficient solution for municipal and industrial users, SafeGuard™ H2O removes Cr(VI), Fe, H₂S, Hg, Pb, and Se from water and wastewater. It also acts as an antibiofilm, antimicrobial reagent for produced water, and as a corrosion inhibitor in distribution networks and cooling systems.

The fully automated SafeGuard™ H2O technology produces a non-toxic stannous reagent onsite and on demand using an in-situ electrolytic generator and a certified precursor. It operates on low power electricity from renewable sources.

This revolutionary system reduces the need for bulk toxic chemicals, it also displaces traditional treatment technologies such as adsorptive media, IEX and RO that are expensive and with significant drawbacks.

The Value of SafeGuard™ H2O

- Fully automated for complete process control and remote performance management 24/7/365
- Incorporates real-time contaminant monitoring
- Certified precursor ensures the quality of the stannous reagent generated
- Produces non-toxic waste streams with low process water loss
- Eliminates waste disposal concerns
- Compact modular design that easily scales and integrates into existing infrastructure
- Energy efficient with low power consumption, optimizes electrical power load balancing
- Powered by renewable energy source



SafeGuard™ H2O On-Site Stannous Generation System

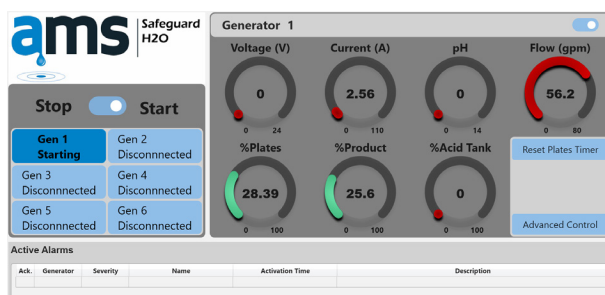

SafeGuard™ H2O Proprietary Control Panel - Running Mode Displayed

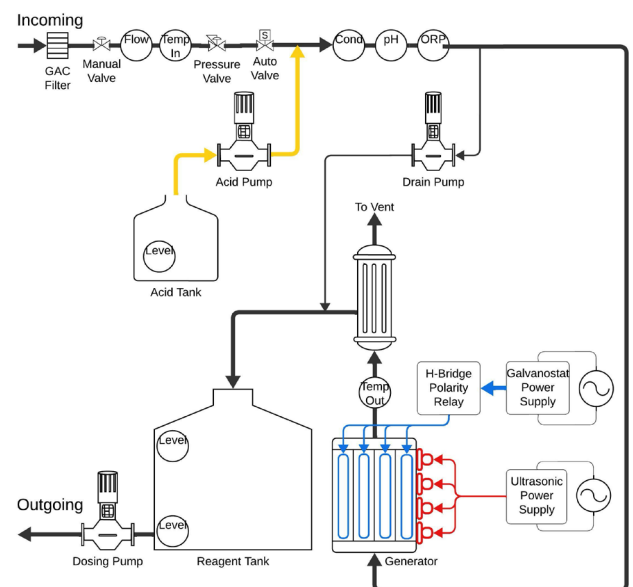

SafeGuard™ H2O Process Flow Diagram



SafeGuard™ H2O On-Site Stannous Generation System Specification

CAPACITY		Full Scale	Demo Unit
Generation Capacity (Tin per Day)	lbs	8.1	0.37
	kgs	3.6	0.17
Stannous Concentration	ppm	700	700
OPERATING ENVIRONMENT		Full Scale	Demo Unit
Control Panel Service (120V AC 50/60 Hz)	amps	20	15
Generator Service (208-240V AC 50/60 Hz) 1-phase	amps	30	15
Generator DC Power Output	Watts	400-1200	50-120
Physical Dimensions (H*W*D)	in	72 x 56 x 24	72 x 24 x 20
	cm	182 x 142 x 60	182 x 60 x 50
Skid Materials for Construction		Carbon Steel Powder-Coated, Stainless-Steel, Steel-Strut Channel	Carbon Steel Powder-Coated, Stainless-Steel, Steel-Strut Channel
Electrical Control Panel		BRX Do-More PLC, Ethernet Communications, Painted-Steel, NEMA 4	
Operator Interface		12" (30 cm) Touch Screen HMI Panel	7" (17 cm) Touch Screen HMI Panel
Hydrogen Dilution Blower		Included	Not Applicable
OPERATING CONSUMABLES		Full Scale	Demo Unit
Acid Consumption (36% HCl)	lbs per lb tin	7.5	7.5
	kgs per kg tin	7.5	7.5
Power Consumption	kWh (AC) per lb tin	1.4	1.4
	kWh (AC) per kg tin	3.0	3.0
Water Consumption	gal per lb tin	165	205
	liters per kg tin	1400	1700
ENVIRONMENTAL CONDITIONS		Full Scale	Demo Unit
Ambient Air Temperature Rating	°F	40-95	
	°C	5-35	
Feed Water Temperature Rating	°F	59-95	
	°C	15-35	
Feed Water Pressure Rating	Psi	10-100	Not Applicable
	kPa	68-690	
APPROVALS		Full Scale	Demo Unit
Electrical Control Panel		NEMA 4, UL508A Control Panel	NEMA 4
Generator		NSF	NSF
WARRANTY		Full Scale	Demo Unit
Factory Warranty		One Year	Not Applicable

* Subject to change without prior notice. Note, the information provided contains general descriptions or characteristics of performance which in actual case of use do not always apply as described.

